

Quantum information science with photons

Takafumi Ono, Ph D, Assistant Professor,
Faculty of Engineering and Design, Kagawa University
Email : ono.takafumi@kagawa-u.ac.jp



Background

Quantum technology has attracted the interest of researchers in recent years due to the insight it provides into fundamental physics as well as due to its relevance to practical applications such as quantum computation, quantum sensing and quantum communication. Progress has been made with superconducting circuits, trapped ions, atoms, photons and spins. Among them, photonic implementation has advantages that it is robust against decoherence and is straightforward to control light at the single photon level.

Approach and Results

Silicon photonics is a promising platform for realizing large-scale quantum photonic devices because of the component density, mature fabrication processing, and compatibility with both telecom optics and CMOS electronics. While the linear optical approach has greatly contributed to this field, it is often possible to improve the functionality and scalability by making use of non-linear processes. Recently, we observed a non-linear interference in the production rate of photon pairs generated from two different four-wave mixing waveguides. We obtain an interference visibility of 97% [1]. This work shows the possibility of integrating nonlinear-optical interference components for silicon quantum photonics.

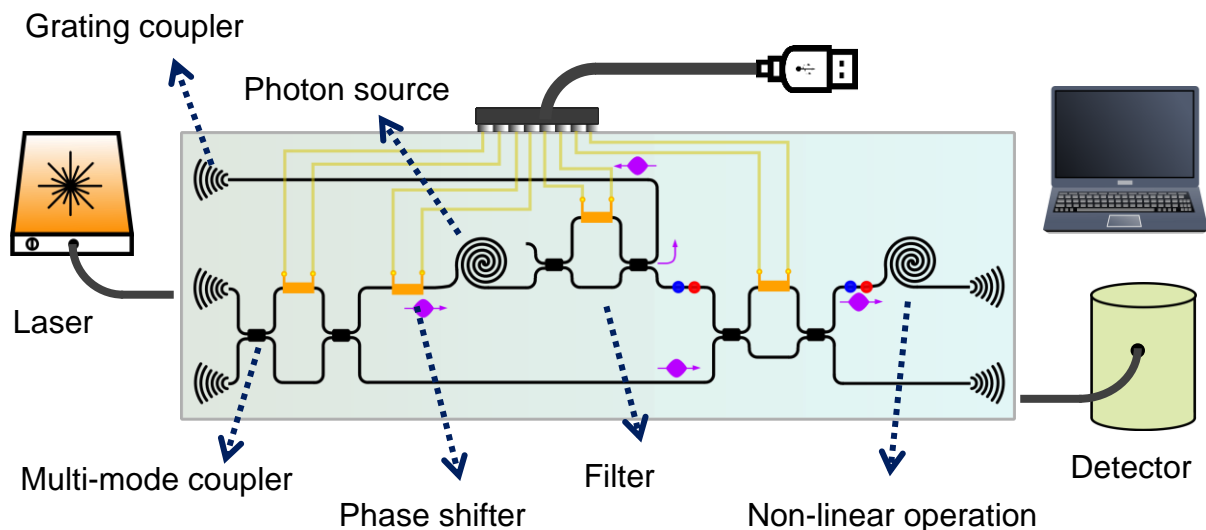

Fig.1: On-chip non-linear interferometer

[1] T. Ono, et. al. Optics Letters, **44**(5) 1277 – 1280 (2019)

Remarks

- Has started the job in Kagawa univ. since last March.
- Academic Society : The Physical Society of Japan, The Japan Society of Applied Physics
- JST PRESTO Researcher [Quantum functionalization]